

1653B/1654B

Performing Live-Circuit Installation Tests on an IT System

Performing the Tests

Voltage measurements

The tester can be used as an ac voltmeter with voltage and frequency displayed at the same time by setting the rotary knob to V. To use the test leads or mains cord, connect the red lead to the L (red) input, the blue lead to the N (blue) input, and the green lead to the PE (green) input. Press F1 and select L-N to display the voltage between phases. Or, select L-PE or N-PE to display the voltage between a phase and the PE connection. Connect the leads or mains cord according to the diagram below. In an IT system, the phase-to-phase voltage is around 230 V. The nominal voltage between each phase and earth is 130 V - this may vary due to the variation of capacitive loading of each phase to earth or due to an existing fault condition.

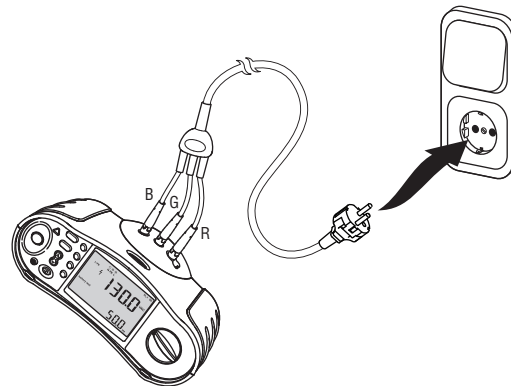
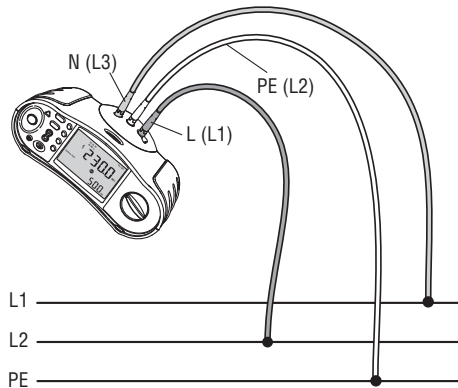

Loop Impedance Measurements

The 1650B series tester can perform two types of loop impedance measurements on an IT-system, phase to phase or phase to earth.

Phase to Phase Loop Measurement

To measure phase to phase, set the rotary knob to Z_1 $\overleftrightarrow{\text{NOTRIP}}$ and select L-N with (F1). To compensate for lead resistance, use the Zero Adapter to short all leads and press (ZERO). To use the test leads, connect the red lead to the L (red) input and the blue lead to the N (blue) input. To use the mains test cord, connect the red lead to the L (red) input, the blue lead to the N (blue) input and the green to the PE (green) input and insert the plug into the outlet. Press (TEST) to initiate a test.

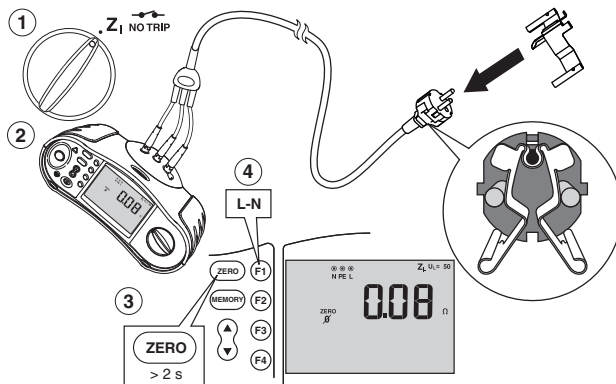

Phase to Earth Loop Measurement

The impedance being measured by a phase to earth test depends on the condition of the IT-system. It should be a very high impedance on a healthy system. Low impedance values may be caused by a shorted disneyter, loads connected to the system, or an existing first fault condition. This is not a common test as the state of the system must be known before you can determine the significance of the measured value.

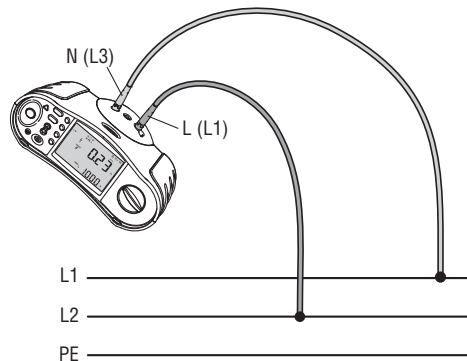

To perform a phase to earth measurement, set the rotary knob to Z_1 NO TRIP and select L N with (F1). To compensate for lead resistance, short all leads and press (ZERO). To use the test leads, connect the red lead to the L (red) input and the blue lead to the N (blue) input. On the circuit to be tested, connect between phase and earth. To use the mains test cord, connect the red lead to the L (red) input, the green lead to the N (blue) input, leave the blue lead unconnected, and insert the plug into the outlet.

Press (TEST) to initiate a test. If the voltage between phase and earth is less than 100 V, testing is disabled. Reverse the plug in the outlet to test the other phase. These tests may trip the RCDs.

The remote probe may be used for either loop impedance test. The test key on the probe performs the same function as the test key on the instrument. This allows tests to be initiated while holding the probes.

RCD Measurements

All RCDs have a test button. When pressing this button a current is generated through the RCD's internal current coil, and the RCD should trip. This test does not verify whether the RCD suitably protects the installation it is in and it does not verify the parametric performance of the RCD. The 165XB series tester can measure the parametric performance of the RCD and determine if it functions correctly in the installation.

There are two types of measurements performed by the 165XB series testers: trip time and trip current. The trip time test (ΔT) forces the selected current and measures the time to trip.

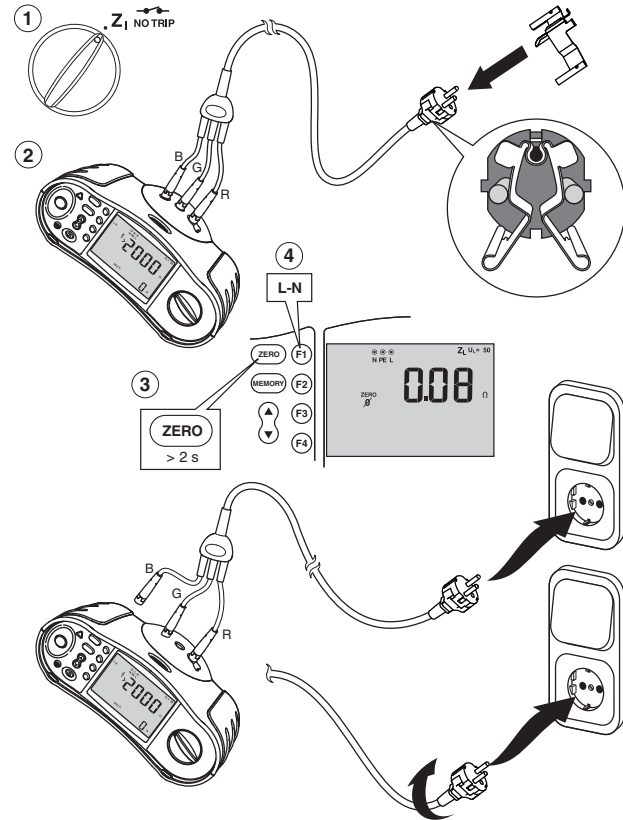

1653B/1654B Instruction Sheet

The trip current test ($I_{\Delta N}$) forces currents from 30 % to 110 % of the selected current to determine the current that causes the RCD to trip. Both tests also display the maximum resulting fault voltage during the test.

To measure trip time, set the rotary knob to ΔT . Select the RCD's rated current (10-1000 mA) with (F1). Select the current multiplier (X1/2, X1, X5) with the (F2) key. Select the RCD type (AC, A, AC & S, A & S, B, or B & S) with (F3). Select the starting phase of the test (0° or 180°) with (F4). Press (TEST) to initiate the test.

To measure trip current, set the rotary knob to $I_{\Delta N}$. Select the RCD's rated current (10-500 mA) with (F1). Select the RCD type (AC, A, AC & S, A & S, B, or B & S) with (F3). Select the starting phase of the test (0° or 180°) with (F4). Press (TEST) to initiate the test.

Type B RCDs can be tested only at the panel. The other types can be tested at the panel or at a socket. To measure at the panel, connect the leads as shown in the upper part of the figure. With all loads on this circuit disconnected, the results are true measurements of the parametric performance of the RCD.

To measure at a socket, use the adapter between the N and the PE inputs. To connect the mains test cord, connect the red lead to the L (red) input and the green to the adapter and insert the plug into the outlet. Press (TEST) to initiate a test. Reverse the plug in the outlet to test the other phase.

If the result is the same in both cases, the measurements are not influenced leakage currents of the circuit. If the

two results are different, the cause might be leakage currents of the circuit. The correct value is approximately the average of the two measurements.

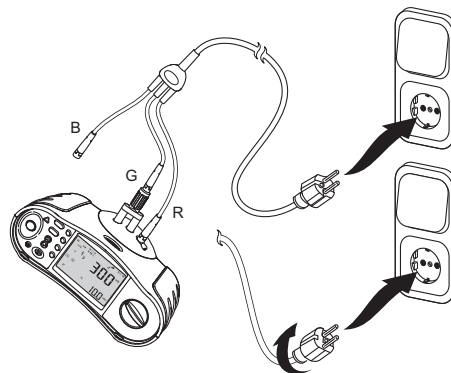
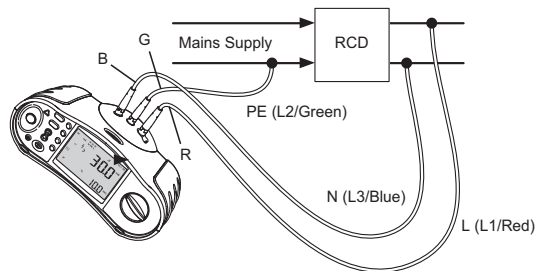

Basic Theory of IT-System Voltage

Voltage

AC sine waves can be described as in Figure 1. We can think of a voltage vector, \hat{U} . This is rotating around in a plane. In a 50 Hz distribution system the rotation time is 20 ms. The vector rotates 360 degrees or 2π radians, which is one period. The next period it repeats itself and we get a periodic signal. We can find the instantaneous voltage with an instrument that measures the voltage at each time. This instantaneous value is often described with small letter (u = the instantaneous voltage value). When the voltage vector has rotated once it draws a momentary value along the time axis. We get a periodic sine wave.

A handheld instrument with a numeric display will only measure the voltage rms value. This value is used for calculating effect. U_{eff} is the voltage rms value. The ratio between the voltage peak and rms value will always be the square root of 2 for a voltage sine wave.

$$U_{\text{eff}} = \frac{\hat{U}}{\sqrt{2}}$$

Figure 1 Voltage

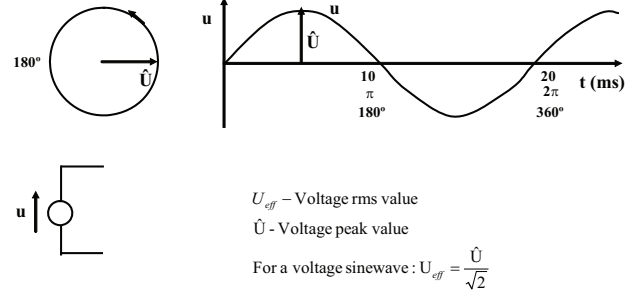

Current Linear Loads

Current will flow in a closed circuit where there is a voltage source that can generate a current. The current is the result of the shape of the voltage and the kind of load. There are three linear loads; resistors, capacitors and coils.

When these loads are connected to a linear voltage, the current will also be linear.

1653B/1654B
Instruction Sheet

When the load is resistive, and the voltage has the shape of a sine wave, the current can be described as a vector that rotates around a plane and draws its instantaneous value along a time axis (as previously described for the voltage). The peak value of the current is the peak value of the voltage divided by the resistance in the circuit. The same is valid for the rms value. For a sine wave current the ratio between peak and rms value is always the square root of 2.

$$I_{\text{eff}} = \frac{\hat{I}}{\sqrt{2}} \Rightarrow \frac{\hat{I}}{I_{\text{eff}}} = \sqrt{2} \Rightarrow \frac{\hat{I}}{I_{\text{eff}}} = 1.414$$

If you have an instrument that can measure both peak and rms values you can verify that the ratio is 1.414. If the ratio differs from 1.414 you can conclude that the current or voltage you are measuring is not a pure sine wave.

In Figure 2 you can see that the current vector has the same direction as the voltage vector. The current is a sine wave and it has its peak value and zero crossing point at the same time as the voltage. The angle between the current and the voltage is zero.

When the load is inductive, see Figure 3, the current value is dependent on the voltage value and the impedance in the circuit. From the figure you can see that the current has an angle of 90° after the voltage.

When the load is capacitive, see Figure 4, the current value is also dependent on the voltage and the impedance in the circuit. In this situation, the current will have an angle of 90° before the voltage.

A three-phase voltage system can be described as in Figure 5. Three-voltage vectors with an angle of 120° between them are rotating around a plane and draw their instantaneous values along the time axis. The phase voltage is measured between the zero point of the voltage source and the phase. The line voltage measured between the phases is 1.732 times larger than the measured phase voltage.

Figure 2 Current resistive loads

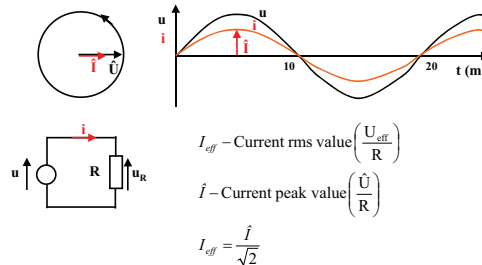

Figure 3 Current inductive loads

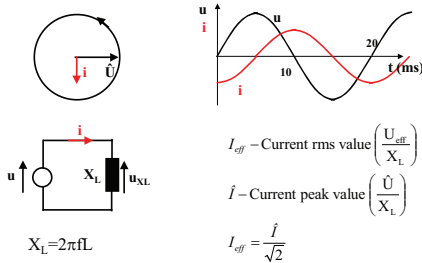
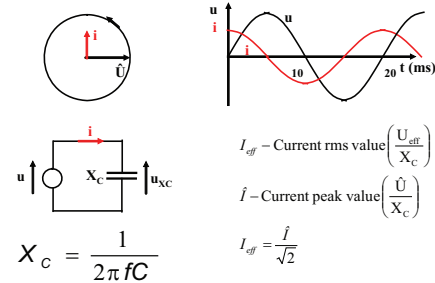

Figure 4 Current capacitive loads



Generally in IT-systems, $U_{1-2} = 230 \text{ V}$ and $U_{1-2-3} = 400 \text{ V}$ and in TN systems $U_1 = 230 \text{ V}$ and $U_{1-2-3} = 400 \text{ V}$.

$$U_{1-2} = U_1 \cdot \sqrt{3} \quad \sqrt{3} = 1.732$$

In Figure 6, the voltage source is loaded with three similar resistors in a star connection. The current in the three phase conductors is equal and has the same angle as the voltage. The center point in the star connection of the load will have the same potential as the center point of the star connection of the voltage supply.

Figure 5 Voltage three phases

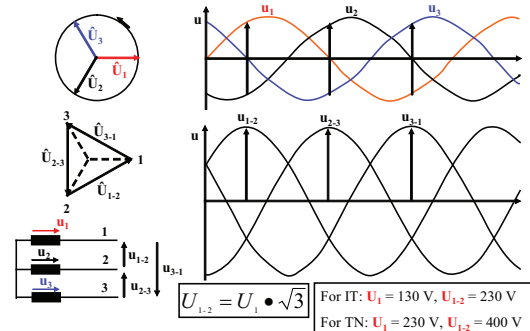

The different phase voltages can be measured between the zero point of the voltage source and each phase, or between the zero point of the load and each phase. The measured value between the zero points and each phase will be equal. If you need to measure the phase voltage you can use three similar resistances connected in a star as in Figure 6. Then you get access to a zero-point and can measure the phase voltage. This method can also be used to measure phase power.

If the loads are unequal, the loads zero point will be displaced related to the voltage source zero point. See Figure 7. The voltage between the loads zero point and the three phases will be unequal due to this displacement.

**Figure 6 Voltage and current, three phases
 Ohmic resistance**

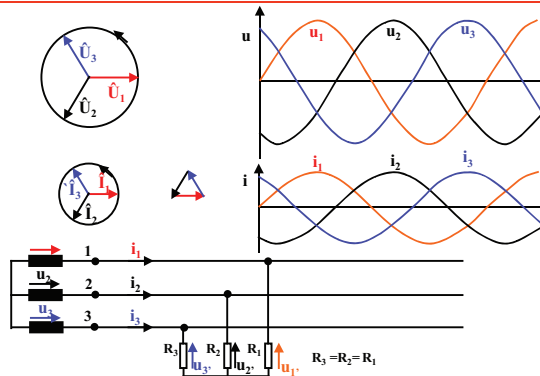
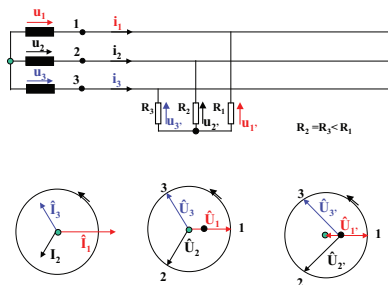

Figure 7 Displacement of the loads zero point



In Figure 8 the three phase voltage source is loaded with three equal capacitances in a star connection. The current in all three phases will be equal and have an angle of 90° before its respective voltage. The star point of the load will have the same potential as the star point of the voltage source. The different phase voltages can be measured between the zero point of the load and each phase, or between the zero point of the load and each phase. The measured value between the zero points and each phase will be equal.

If the loads are unequal, the load's zero point will be displaced relative to the voltage source zero point. See Figure 9. The voltage between the load's zero point and the three phases will be unequal due to this displacement.

**Figure 8 Voltage and current, three phases
 Capacitive load**

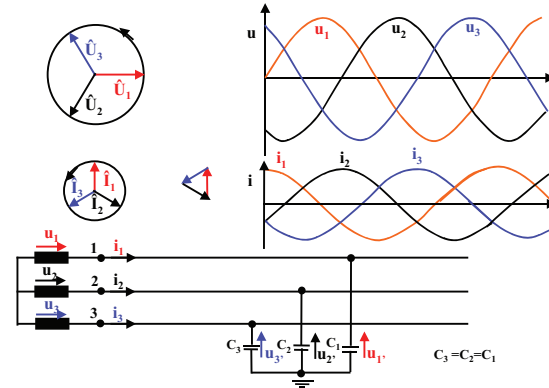
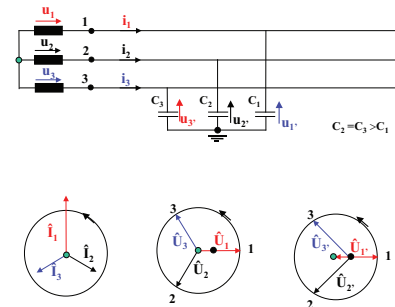

Figure 9 Displacement of the loads zero point



Earth-Fault

In an IT-system, the zero point of the transformer is not connected to earth. Earth is connected to the system through the capacitive coupling each phase has to earth. Normally the common point of the transformer is connected to earth through an over voltage protection unit called a disneyter. See Figure 10. This will start conducting when the voltage between the zero point and earth increases more than a certain value. Otherwise, it works as an insulator.

When measuring voltage between each phase and earth in the IT-system we are actually measuring the voltage over this coupling capacitance. If we are measuring equal voltage between each phase and earth, we can make two different conclusions:

1. There is no earth fault in the transformer circuit. The capacitive coupling between each phase and earth is equal for the three phases.
2. If the disneyter is defective, it will make a connection between the common point of the transformer and earth (this then becomes a TT system). In this case, we will be measuring the phase voltage from the transformer and it will be equal for all three phases.

For IT-systems, when measuring the voltage between phase and earth we get a voltage quite similar to the phase voltage (across the phase to the common point of the transformer). If we get a resistive earth-fault in one of the phases, the earth potential will move along a semi-circle around that phase vector. Where the earth potential

will be depends on the size of the resistance and the capacitive coupling to earth.

Figure 10 IT system

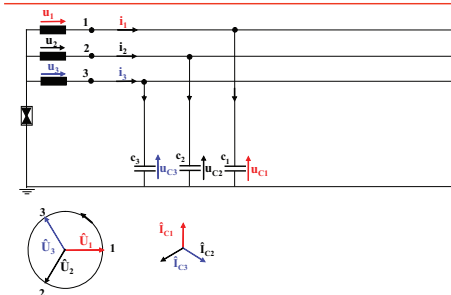
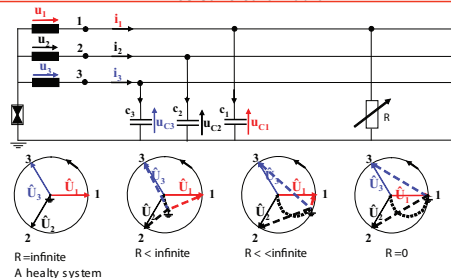

Figure 11 Voltage between phase and earth.
 Resistive earth-fault



In Figure 11 a resistive fault from phase 1 to earth exists. The earth potential has moved along the semi-circle. As the resistance is reduced, the earth potential moves further away from the zero point of the transformer, along the semi-circle. We can measure a voltage that is 242 V between earth and one of the other phases in this situation. Finally, as the resistance decreases to zero, we have a short between earth and phase 1 and we will not measure any voltage between them. Between earth and the other phases we measure the line voltage of 230 V.

In reality, a fault may be caused by a device that is both inductive and resistive, for example, a current limiter in a lighting fixture. This will have the effect of moving the voltage of the common point of the transformer along the lines of Figure 12. Then the voltage between earth and the different phases can be more than 400 V.

When there is a short between phase and earth in an IT-system, the current is defined by the total resistance in the fault loop and the capacitive coupling the system has to earth. The current will follow a path as shown in Figure 13. The current will change dependent of the capacitive coupling the healthy phases have to earth. Normally this current is quite low and it will not trip overload protection units.

When there is a short between two phases in an IT-system, the current is limited by the impedance in the fault loop, the external impedance Z_{ytre} , plus the impedance in the conductors, Z_{indre} . See Figure 14. Z_{ytre} is the impedance of transformers and the wiring system upstream of the origin of the installation. Z_{indre} is the

impedance in and wiring system downstream the origin of the installation.

Figure 12 Voltage between phase and earth.
Resistance and coil earth-fault

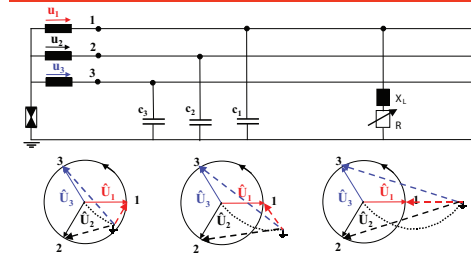
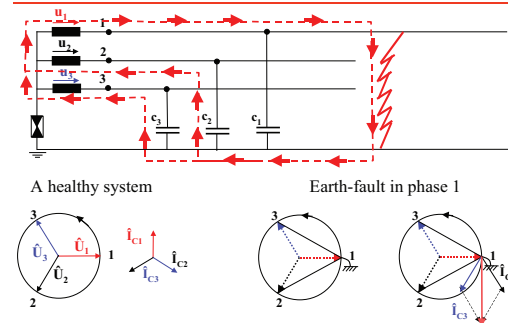

Figure 13 Fault-current between phase and earth



We can use an installation tester to verify the PSC current and loop-impedance between the phases in an IT-system. The installation tester simulates a fault and calculates the impedance and PSC. To get an indication on the I_{k2p_min} you can measure at the end of the circuit and multiply the result with 0.76.

To get an indication on the three-phase value, I_{k3p_maks} , you can measure at the point of origin and multiply the result with 1.15. The reason the results are indications only is that these factors are based on ideal situations regarding voltage and temperature.

Capacitive Leakage Currents

In all mains systems we have capacitive coupling between phases and earth. This capacitive coupling can be composed of conductor insulation or capacitive loads. The result is that the system is loaded with a capacitive leakage current. This current is present even if there are no other loads connected. More developed systems will have larger capacitive coupling, and the leakage current will be larger.

If the capacitive coupling is the same between each phase and earth, earth will have the same voltage potential as the zero point of the transformer.

The current through each capacitance will have an angle of 90° before its respective voltage. There will also be equal voltage between each phase and earth. If the capacitive coupling between each phase and earth is different, the voltage between each phase and earth will be different.

Figure 14 PSC in an IT system

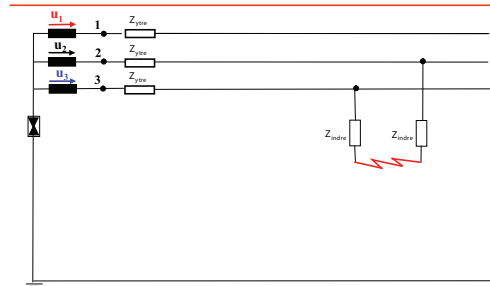
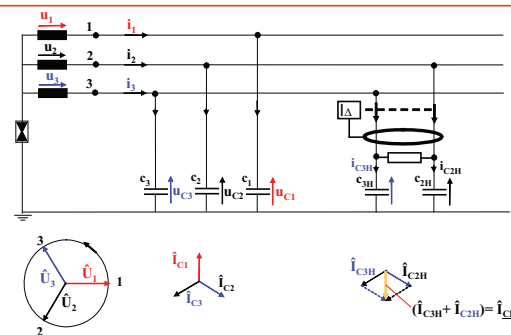

Figure 15 Leakage current in an installation



The magnitude of the leakage current is dependent on the capacitive coupling each phase has to earth. For example, in a standard house with an IT-system, this leakage current can be 10mA. This current consists of two capacitive components with an angle of 90° before its respective phase current. The angle between the two components is 120° . See Figure 15.

RCDs in IT-Systems

NEK400:2002 pinpoints a requirement to disconnect earth-faults in final circuits connected to a public network transformer. The practical solution is often the use of RCDs before the fault.

Before a RCD is tested, any load downstream from the RCD must be disconnected because all loads have a leakage current to earth. This leakage current will be added to the test current generated by the test instrument and influence the measurements. This is due to the fact that most installation testers with a RCD function work as shown in Figure 16. The instrument adds a resistive load between one phase and earth. The current forced by the tester is in phase with the phase voltage connected to earth via the resistors added from the instrument. It is the total of testers generated current and any leakage currents that trip the RCD. The result can depend on which phase the tester connects to earth. On one of the phase the tripping current may be less than the true characteristic of the RCD and on the other it may be greater. The correct value is approximately the average of the two measured values.

Figure 16 Testing a RCD

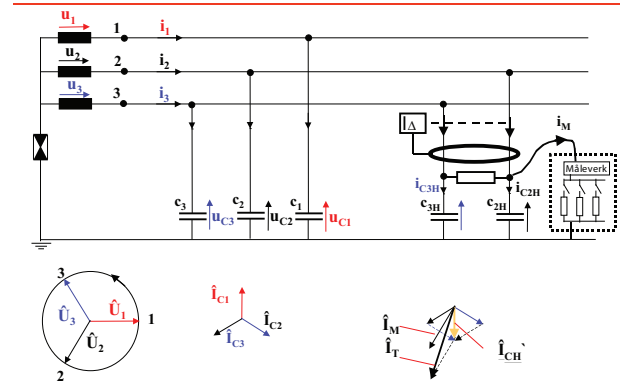

1653B/1654B

Instruction Sheet

It may be possible that the RCD does not trip. There might be a problem with the RCD, but this is seldom the case. More likely the cause is that the RCD is placed incorrectly. If, for example, a three phase RCD is placed too close to the transformer it will not trip. See Figure 17.

In an IT-system, the earth-fault current is determined by the capacitive coupling each phase has to earth. NEK 400 recommends that the first earth-fault current in a transformer circuit is calculated to be 2 mA per kVA transformer size. Sometimes the capacitive coupling is so small that an earth-fault current never reaches the value that is needed to trip the RCD. This often happens in little developed systems.

Sometimes the RCD will trip without any downstream earth-faults. The reason might be that the capacitive leakage current is so large that it makes the RCD trip.

As already discussed, all loads have a natural leakage to earth. This current can be measured with a leakage current clamp.

